

# *Intralogistics*

Optimised with Lenze



**Lenze**

# Lenze applications | in intralogistics

**Whether continuous or intermittent or involving lifting or lowering, moving or positioning, seamless internal material flow is critical for many production processes. With this in mind, efficient conveyors are vital, safeguarding the connection to upstream and downstream systems.**

Geared motors with and without frequency inverters are used, for example, to drive conveyor belts of all different types. Lenze has an impressive portfolio of modules and solutions to enable you to increase the productivity of logistical systems. Drive components are selected on the basis of criteria such as required power or required dynamic performance, as well as your own specific requirements.

So why not draw on our experience to maximise reliability and cost-effectiveness?

Whether a helical-bevel gearbox with forced ventilated asynchronous servo motor or a shaft-mounted helical gearbox with non-ventilated asynchronous servo motor is the order of the day, interplay between components can be taken as read for both centralised and decentralised machine concepts. Lenze has a reputation for tailor-made, powerful and high-quality drive solutions the world over, a single source to meet all of your electronic and mechanical needs.

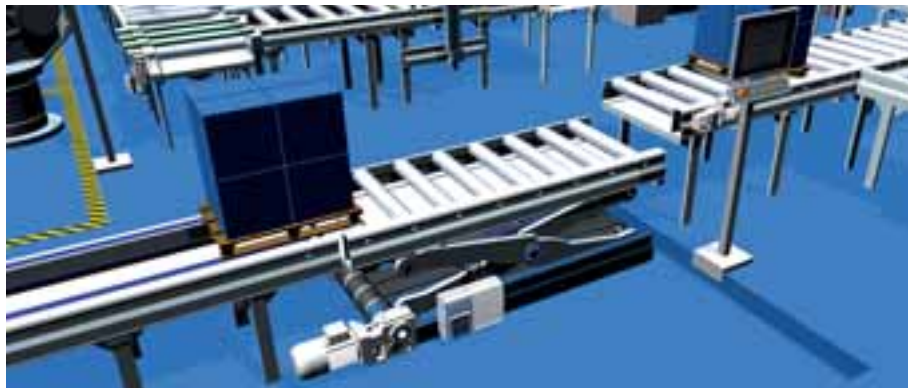

*Standard hoists*



*Storage technology*



## Important developments at a glance

**Lenze's many years of experience in materials handling technology, countless projects and intensive dialogue with customers and insiders places the company at the cutting edge of developments in intralogistics.**

### Safety engineering

The moving parts of a machine pose a danger to personal safety. That is why Lenze starts integrating safety functions from the drive level up. Lenze inverters are certified with functional safety engineering corresponding to the new regulations EN ISO 13849-1 and EN 62061 as standard. This makes it much easier for the entire machine to pass acceptance testing by the TÜV or Employer's Liability Insurance Association, for example.

### Energy efficiency

Virtually every area of the production process and every aspect of automated material transport and the plant infrastructure is reliant on electric drives. Given that electric drives account for such a high proportion of overall consumption and are in such widespread use, they are also the most effective means of increasing energy efficiency in industrial applications. In fact, by using intelligent solutions, energy consumption can be reduced by more than 20%.

### Lenze BlueGreen Solutions

Saving energy is one of the toughest challenges of today and the future. Lenze is facing up to this responsibility.

With Lenze BlueGreen Solutions, we are showing you how to use drives to save energy. Our solutions take the entire drive system into account, offering compatible, thoroughly efficient and co-ordinated products.

#### ► Precision drive dimensioning

In addition to co-ordinated components, Lenze offers in-depth know-how. The Drive Solution Designer (DSD) can tailor the drive system specifically to meet the requirements of your application. Expected energy consumption is recorded in the Energy Performance Certificate for drive solutions.

#### ► ErP directive for energy-related products

Statutory minimum efficiency levels for three-phase AC motors will come into effect in the EU in June 2011. To help you get to grips with this important regulation, Lenze has produced a brochure containing answers to frequently asked questions.

# Typical solutions | optimised by Lenze

## Roller conveyors running at constant speed

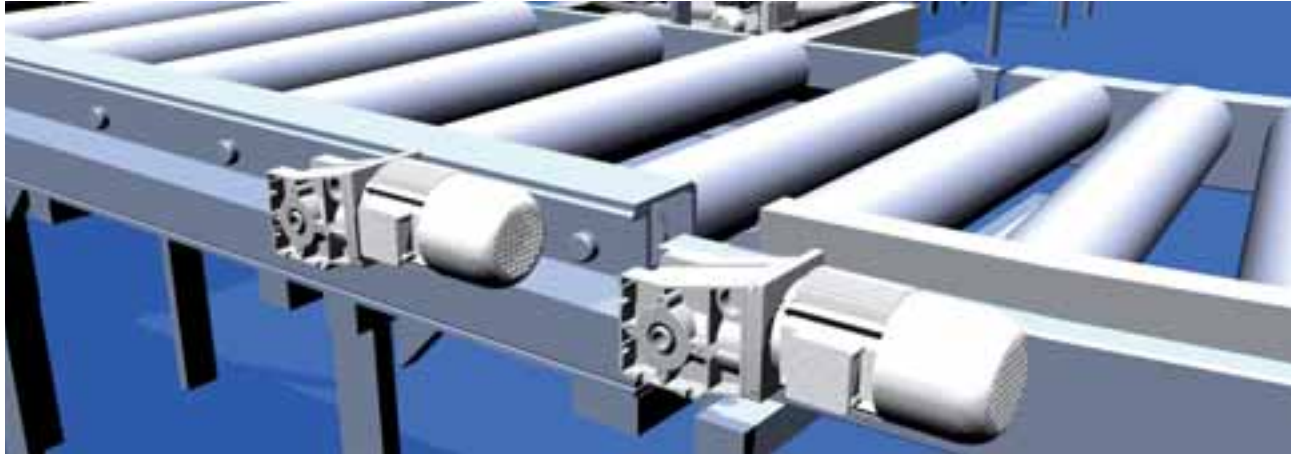

### The application

Three-phase geared motors connected directly to the mains are the ideal solution for roller conveyors running at constant speed.

**A solution of this type can be implemented using for example** a GKR bevel geared motor with an MH three-phase AC motor

### The benefits for you

- ▶ Straightforward, efficient drive solution
- ▶ Energy-efficient thanks to the high efficiency of the helical-bevel geared motor (96% throughout the entire speed range)
- ▶ Motor efficiency class IE2

### GKR bevel geared motor



- ▶ 2-stage geared motor with solid or hollow shaft with foot and flange mounting
- ▶ Low-noise and low-wear gear system
- ▶ Power range 0.06 ... 7.5 kW
- ▶ Rated torque 45 ... 450 Nm
- ▶ Ratio 3.4 ... 76

### MH three-phase AC motor, efficiency class IE2



- ▶ Sizes 080... 200, 4-pole
- ▶ Power range 0.75 ... 30 kW
- ▶ As a geared motor or in designs B3, B5 and B14
- ▶ IP55 enclosure
- ▶ Efficiency class IE2
- ▶ Optional UL/CSA approvals

## Variable-speed belt conveyor

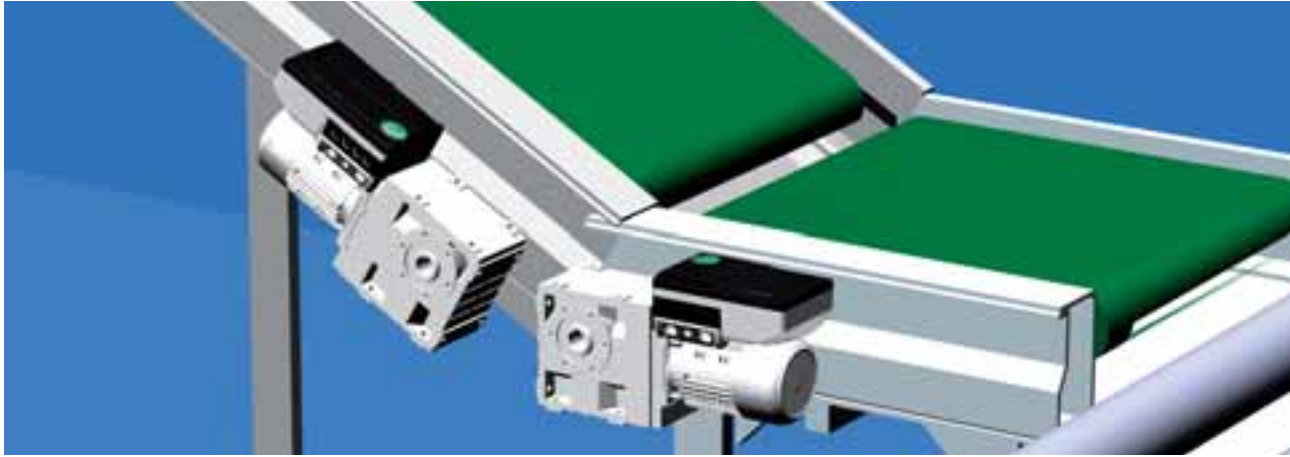

### The application

Horizontal or inclined belt conveyors for bulk goods or loose materials use a frequency inverter to safeguard the smooth starting and speed control of the geared motor.

### A solution of this type can be implemented using for example

- ▶ Inverter Drives 8400 motec
- ▶ GKS helical-bevel geared motor with MF three-phase AC motor

### The benefits for you

- ▶ Connection is straightforward on or close to the motor and does not require a control cabinet
- ▶ Pluggable memory module makes it easy to replace drives
- ▶ MF asynchronous motor with wide setting range is incredibly compact and the ideal solution.
- ▶ VFC eco energy-saving function saves energy in no-load or partial-load operation

### Inverter Drives 8400 motec



- ▶ Decentralised frequency inverter in IP55 or IP66 enclosure
- ▶ Power range 0.37 ... 1.5 kW
- ▶ Mains voltages up to 550 V
- ▶ Fieldbus and terminal control
- ▶ Wall and motor mounting are possible

### GKS bevel gearbox, combined with MF three-phase AC motor



- ▶ Sizes 063 ... 132, 4-pole
- ▶ Power range 0.55 ... 22 kW
- ▶ As a geared motor or in designs B3, B5 and B14
- ▶ IP55 enclosure
- ▶ High-efficiency three-phase AC motor
- ▶ Optional UL/CSA approvals

## Rotary table



### The application

Typical tasks performed by rotary tables are injection and ejection, storage and sorting. Their pivot-mounted supporting bases are driven by a geared motor directly, via a driving wheel or by a pinion mounted on the motor shaft.

### A solution of this type can be implemented using for example

- ▶ Inverter Drives 8400 StateLine
- ▶ GKS helical-bevel geared motor

### The benefits for you

- ▶ Integrated switch-off positioning with sensor evaluation
- ▶ Process optimisation thanks to acceleration and deceleration ramps which can be set separately
- ▶ High gearbox efficiency of up to 94%
- ▶ Easy to service thanks to pluggable memory module and pluggable connections

### Inverter Drives 8400 StateLine



- ▶ Power range 0.25 ... 45 kW
- ▶ Integrated brake management
- ▶ Integrated brake transistor
- ▶ Safe standstill (STO) available as an option
- ▶ Fieldbus communication

### GKS helical-bevel geared motor



- ▶ 3-stage and 4-stage geared motor with solid or hollow shaft with foot and flange mounting
- ▶ Optional integrated torque plate including rubber buffer
- ▶ Power range 0.12 ... 45 kW
- ▶ Rated torque 190 ... 11,790 Nm
- ▶ Ratio 5 ... 1510

## Scissor lift table



### The application

Scissor lift tables are used for limited vertical movement. For design reasons, helical-bevel gearboxes combining low overall height and optimised speed/torque delivery are required.

### A solution of this type can be implemented using for example

- ▶ Inverter Drives 8400 protec
- ▶ GKL helical-bevel geared motor

### The benefits for you

- ▶ Decentralised intelligence relieves the load on the system control
- ▶ Wall mounting with pluggable connections
- ▶ Decentralised topologies can be set up without a control cabinet

### Inverter Drives 8400 protec



- ▶ Decentralised frequency inverter enclosed to IP65
- ▶ Power range 0.75 ... 4.0 kW
- ▶ Pluggable connection system
- ▶ Safety engineering to EN ISO 13849-1
- ▶ Wear-free brake control

### GKL helical-bevel geared motor



- ▶ 3-stage and 4-stage geared motor with solid or hollow shaft with foot and flange mounting
- ▶ Power range 0.12 ... 22 kW
- ▶ Rated torque 190 ... 2800 Nm
- ▶ Ratio 18 ... 200

## Lifting station



### The application

Lifting stations move goods vertically across long distances, thereby bridging significant differences in height. The drive mechanisms with wire ropes or belts as a means of traction are dimensioned on the basis of the lifting height.

### A solution of this type can be implemented using for example

- ▶ Inverter Drives 8400 HighLine
- ▶ GST helical geared motor

### The benefits for you

- ▶ High-precision point-to-point positioning
- ▶ Evaluation of two HTL encoders for motor control plus belt slip and brake monitoring
- ▶ Holding of the load at standstill by the motor and wear free brake management
- ▶ Easy to service thanks to pluggable memory module and pluggable connections

### Inverter Drives 8400 HighLine



- ▶ Power range 0.25 ... 45 kW
- ▶ Integrated safety engineering "Safe Torque Off (STO)" available as an option
- ▶ 2x overload capacity for 3 s;  
1.5x overload capacity for 60 s
- ▶ Positioning control with up to 15 target positions

### GST helical geared motor



- ▶ 1-stage, 2-stage and 3-stage geared motor with solid shaft plus foot and flange mounting
- ▶ High permissible radial forces
- ▶ Power range 0.06 ... 45 kW
- ▶ Rated torque 45 ... 5920 Nm
- ▶ Ratio 1.6 ... 435
- ▶ Efficiency up to 98%

## Storage and retrieval unit

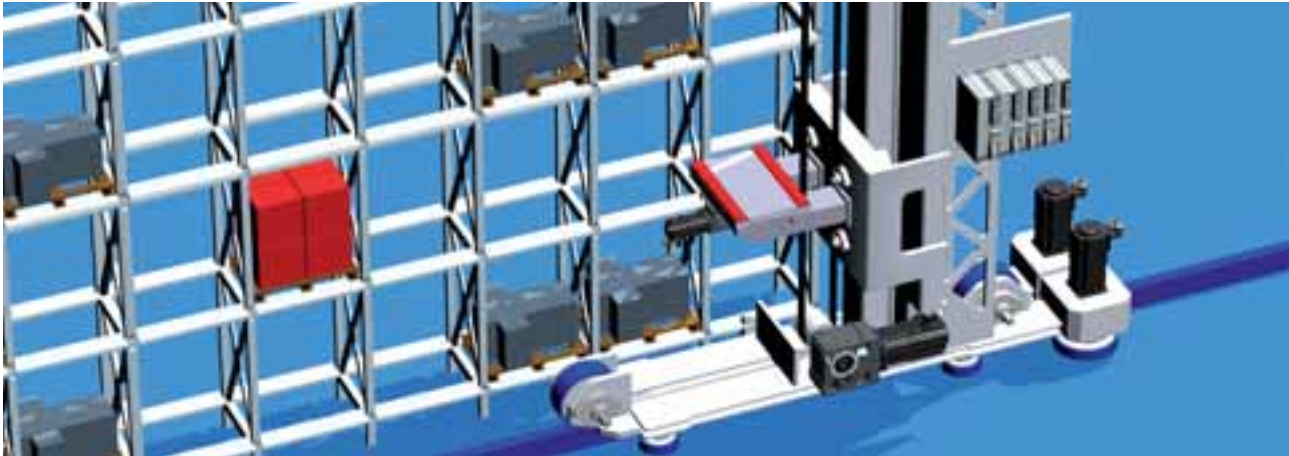

### The application

Storage and retrieval units are rail-guided, single-track vehicles which distribute and remove goods in high-bay warehouses.

### A solution of this type can be implemented using for example

- ▶ Servo Drives 9400 HighLine
- ▶ GKS helical-bevel geared motor
- ▶ MCS and MCA servo motors

### The benefits for you

- ▶ Precision synchronised running of anti-oscillation lifting drive and travelling drive by electric gearbox
- ▶ Energy saving thanks to DC-bus connection for lifting drive and travelling drive
- ▶ Mains regenerative feedback via adapted modules
- ▶ Various feedback systems can be used; resolvers, HTL encoders, SinCos encoders, Hyperface, etc.
- ▶ Integrated PLC and tested technology functions

### Servo Drives 9400 HighLine



- ▶ Power range 0.37... 370 kW
- ▶ Single-axis and multi-axis applications
- ▶ Pluggable memory module for parameter setting
- ▶ Integrated safety to EN ISO 13849-1

### GKS helical-bevel geared motor with MCS and MCA servo motors



- ▶ 3-stage and 4-stage geared motor with solid or hollow shaft with foot and flange mounting
- ▶ Power range 0.12 ... 53.8 kW
- ▶ Rated torque 190 ... 11,790 Nm
- ▶ Ratio 5 ... 1510

## Palletising systems

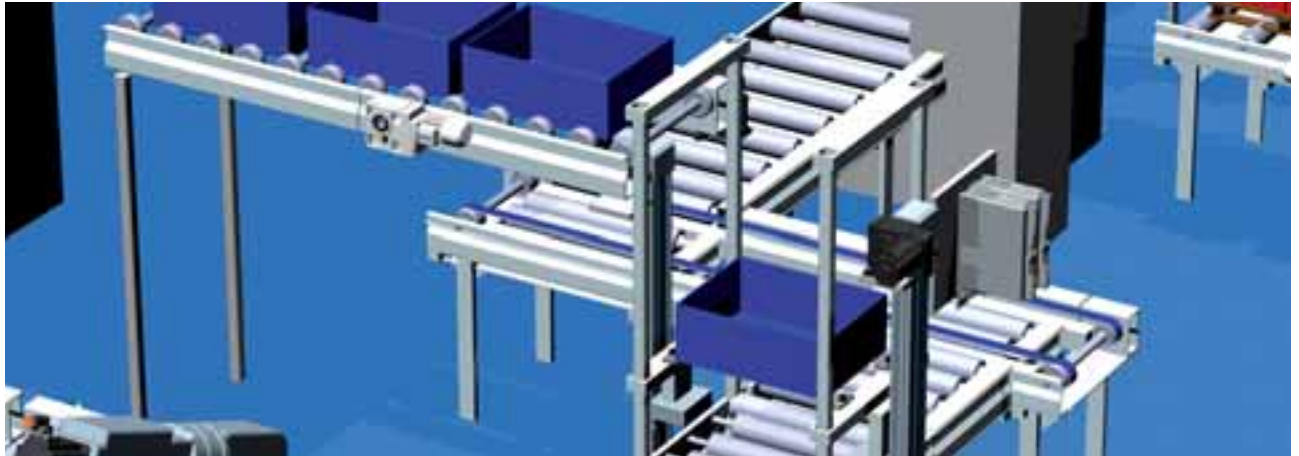

### The application

Palletising systems are used for precision handling of packaging units at the end of a production process. They often have to support heavy weights and must meet high demands in terms of dynamic performance and positioning accuracy.

### A solution of this type can be implemented using for example

- ▶ Servo Drives 9400 HighLine
- ▶ GFL shaft-mounted helical geared motor
- ▶ MCS and MCA servo motors

### The benefits for you

- ▶ Process improvements thanks to technology functions for motion control tasks
- ▶ Energy exchange in the multi-axis DC-bus connection with regenerative power supply unit

### Servo Drives 9400 HighLine



- ▶ Power range 0.37 ... 370 kW
- ▶ Single-axis and multi-axis applications
- ▶ Pluggable memory module for parameter setting
- ▶ Various technology applications (positioning sequence, cam, etc.) and free function block interconnection
- ▶ Integrated safety to EN ISO 13849-1

### GFL shaft-mounted helical geared motor with MCS and MCA servo motors



- ▶ 2-stage and 3-stage parallel axis geared motor with solid or hollow shaft, foot and flange mounting
- ▶ Power range 0.12 ... 53.8 kW
- ▶ Rated torque 190 ... 11,600 Nm
- ▶ Ratio 3.5 ... 856

## Monorail overhead conveyor and automated guided vehicle systems

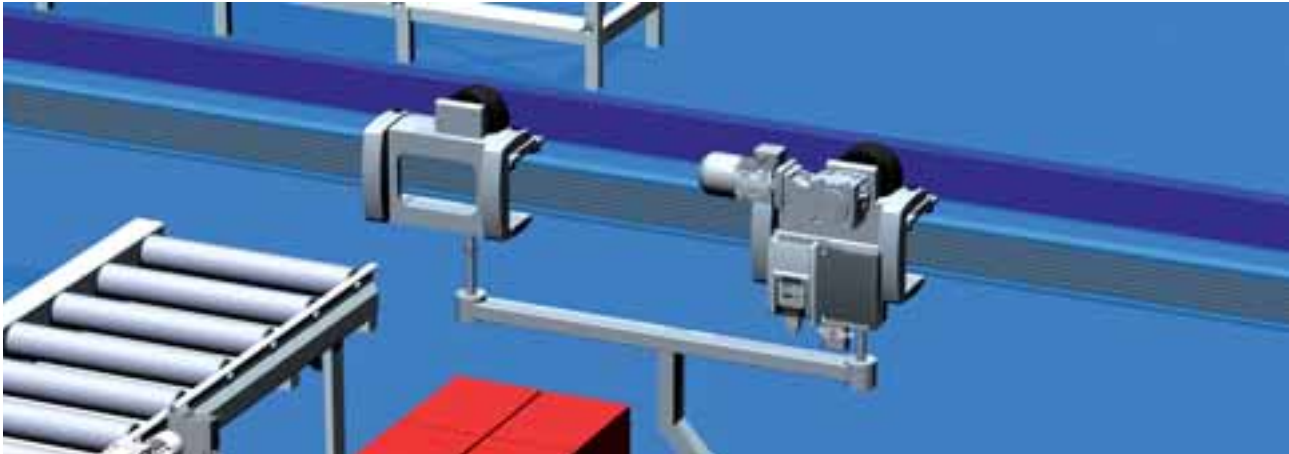

### The application

Intelligent control enables monorail overhead conveyors to approach their destinations automatically. The tracks required by this flexible and floorless means of transport are mounted on ceilings or pillars.

### A solution of this type can be implemented using for example

- ▶ Inverter Drives 8400 protec EMS
- ▶ GKK bevel geared motor

### The benefits for you

- ▶ Perfectly harmonised mechanical and electrical system solution for monorail overhead conveyors from a single source
- ▶ Various feedback systems can be used; resolvers, HTL encoders, SinCos encoders, Hyperface, etc.
- ▶ Integrated PLC

### Inverter Drives 8400 protec EMS\*



- ▶ Power range 0.75 ... 4.0 kW
- ▶ Slip-ring transmission of data and energy on the energy cable
- ▶ Alternative: Inductive energy and data transfer
- ▶ All connections are pluggable
- ▶ Modular and flexible

### GKK bevel geared motor (EMS)



- ▶ 3-stage and 4-stage geared motor
- ▶ With disconnect clutch
- ▶ Power range 0.12 ... 5.5 kW
- ▶ Rated torque 70 ... 900 Nm
- ▶ Ratio 7.7 ... 86.8

\*Available as of April 2011

# It's good to know | why we are there for you



*"Our customers come first. Customer satisfaction is what motivates us. By thinking in terms of how we can add value for our customers we can increase productivity through reliability."*



*"We will provide you with exactly what you need – perfectly co-ordinated products and solutions with the right functions for your machines and installations. That is what we mean by 'quality'."*



*"Take advantage of our wealth of expertise. For more than 60 years now we have been gathering experience in various fields and implementing it consistently and rigorously in our products, motion functions and pre-configured solutions for industry."*



*"The world is our marketplace. Wherever you are in the world, we are nearby, providing you with our drive and automation solutions."*

Algeria · Argentina · Australia · Austria · Belarus · Belgium · Bosnia-Herzegovina · Brazil · Bulgaria · Canada · Central America · Chile · China · Colombia · Croatia · Czech Republic · Denmark · Egypt · Estonia · Finland · France · Germany · Greece · Hungary · Iceland · India · Indonesia · Iran · Israel · Italy · Japan · Latvia · Lebanon · Lithuania · Luxembourg · Macedonia · Malaysia · Mauritius · Mexico · Morocco · Netherlands · New Zealand · Norway · Philippines · Poland · Portugal · Romania · Russia · Serbia-Montenegro · Singapore · Slovak Republic · Slovenia · South Africa · South Korea · Spain · Sweden · Switzerland · Syria · Taiwan · Thailand · Tunisia · Turkey · Ukraine · United Arab Emirates · United Kingdom/Eire · USA · Vietnam

**You can rely on our service. Expert advice is available 24 hours a day, 365 days a year, in more than 30 countries via our international helpline: 008000 24 Hours (008000 2446877).**

**[www.Lenze.com](http://www.Lenze.com)**

13352686