

L-force

Inverter Drives 8400 protec



On site and all systems go!

NEW

Lenze

L-force | Decentralised drives

The major challenges of the future are to be found in the areas of cost efficiency, time-saving and quality improvement. Customers expect faster project planning and commissioning, better performance and more flexibility in production. Lenze is rising to these challenges with its L-force drive and automation family by offering a holistic portfolio of solutions along with coordinated interfaces and components.

One of the latest additions to the portfolio is the 8400 protec range from the Inverter Drives 8400 family of decentralised drive technology. It offers numerous advantages and significant cost-cutting potential for systems distributed across large areas in particular, as functionality can be transferred to the exact locations where they are required. Other benefits include minimising control cabinet space, keeping motor cables short, reducing cooling overheads and dealing with complex system structures in a clear and transparent way.

Rugged design, high levels of operational reliability and rapid installation are the kinds of positive features you would expect from Lenze. With the new 8400 protec range, these are supplemented by integrated functions, three examples of which are safety on board, positioning technology and complete sequence control for use in monorail overhead conveyors.

The compact design and high degree of protection offered by the new decentralised generation make it ideal for applications in the automotive, logistics and printing sectors.

As the 8400 protec StateLine and HighLine stages support the same functional scope as the control cabinet units in the Inverter Drives 8400 range, integration can be tailored with regard to both functions and price. Available communication options include PROFINET IO to Conformance Class B (CC-B) and the PROFIsafe protocol.

Power range

- ▶ 0.75 to 1.5 kW
- ▶ 3.0 to 4.0 kW

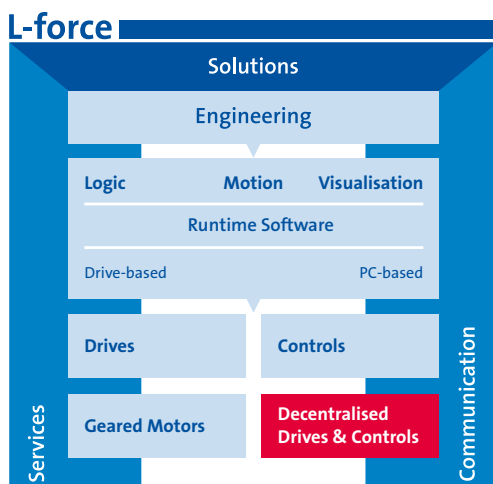

8400 protec –
two different frame sizes

All systems go! | making the case for decentralisation

Decentralised drive solutions save valuable time during installation, commissioning and in the event of service – in other words, at all stages of the value-added chain. In this regard, Lenze's new drive solution, the "8400 protec", is a real innovation.

Highlights

Plug and drive

Unpack, plug in – ready to go. All connections on the 8400 protec – from the shielded motor cable to the power supply and even the fieldbus link and the connection for the sensors – are fitted with standard plug-in connectors. As a result, installation takes less time and overall system availability is increased.

A systematic approach to efficiency

The expansion of the 8400 inverter platform to include a decentralised option offers users cost advantages all along the value-added chain, as product features are standard throughout.

Design engineers, operators and service personnel need to be trained just once in order to be able to use all of the products on the platform. This saves valuable time not only where project planning and commissioning are concerned, but also in live operation.

Immediate diagnostics on site

The 8400 protec makes a further contribution to increasing plant availability thanks to its excellent diagnostics options, which include status LEDs and a clearly visible display.

Safety on board

A standard feature on the 8400 protec is safety engineering scaled in line with functions. This supports direct connection of safety sensors, options for connection to PROFIsafe and even freely selectable drive responses. The range meets the performance level requirements of EN ISO 13849-1 and conforms to SIL 3 to IEC 61508.

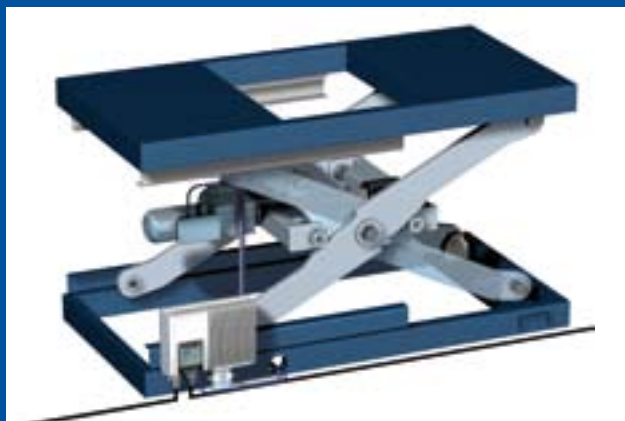

Scissor-type lift table – solved with 8400 protec



Monorail overhead conveyor – solved with 8400 protec

8400 protec | a highly compact product that achieves so much more

IP65 enclosure, rugged and compact structure, easy handling, integrated safety engineering and brake control, pluggable connections, high availability, scaled functional scope.

A cost-effective solution for mechanical and systems engineering wherever space is at a premium.

The advantages

- ▶ Standardised plug-in connectors
- ▶ Shorter motor cables
- ▶ Reduced power losses
- ▶ Improved EMC
- ▶ Minimum control cabinet space
- ▶ Reduced cooling requirements
- ▶ Pluggable memory module
- ▶ Parameterisable with L-force Engineer

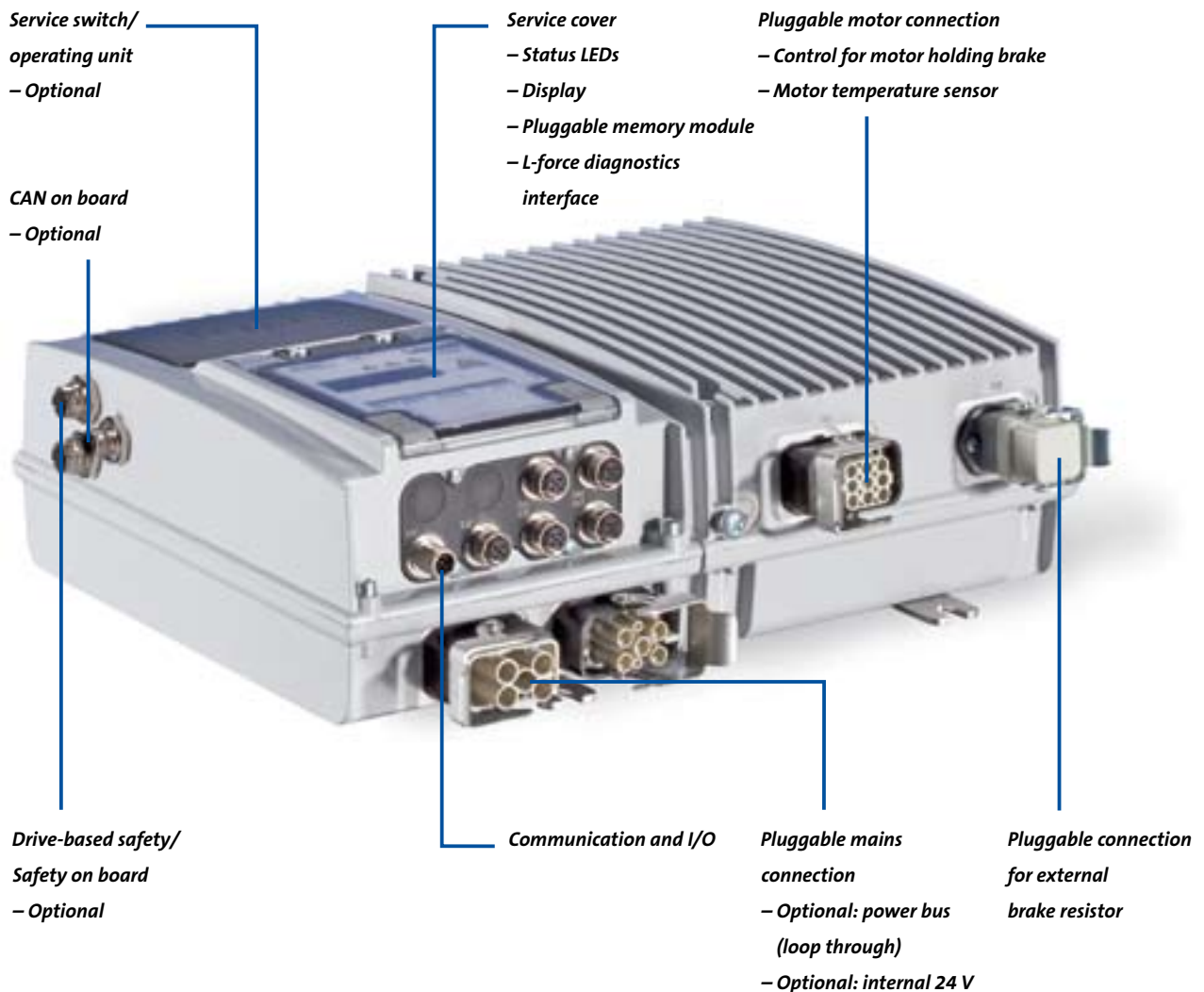

Decentralised | innovations on a tried and tested platform

Inverters with advanced functionality support servo-oriented applications. The 8400 protec comes complete with all modules and interfaces ready to be connected.

Decentralised and integrated positioning
Cost-effective and decentralised positioning applications really can be implemented with asynchronous motors. The 8400 protec offers integrated solutions for applications involving switch-off positioning, table positioning and absolute positioning. Support for the connection of incremental and absolute value encoders completes this functional range. Parameter settings can be made conveniently using the “L-force Engineer”. The range features freely-editable function block interconnection for the integration of logic, arithmetic and mathematical programs by means of graphics-based programming.

Online diagnostics and memory module
The DIP switches for the bus address and baud rate, the diagnostics interface and the memory module (the central memory unit for all of the inverter's parameters) are located behind the service flap on the front panel. The memory module is parameterised prior to commissioning and is then plugged in. In the event of service, it is simply a question of replacing the drive.

Safety engineering to EN ISO 13849-1
In addition to support for the connection of local safety elements and safe communication over PROFI-safe, the certified safety engineering also offers a range of safety functions

- ▶ Safe torque off (STO)
- ▶ Safe stop 1 (SS1)
- ▶ Emergency stop (SSE)
- ▶ Safe operation mode selector (OMS)
- ▶ Safe enable switch (ES)

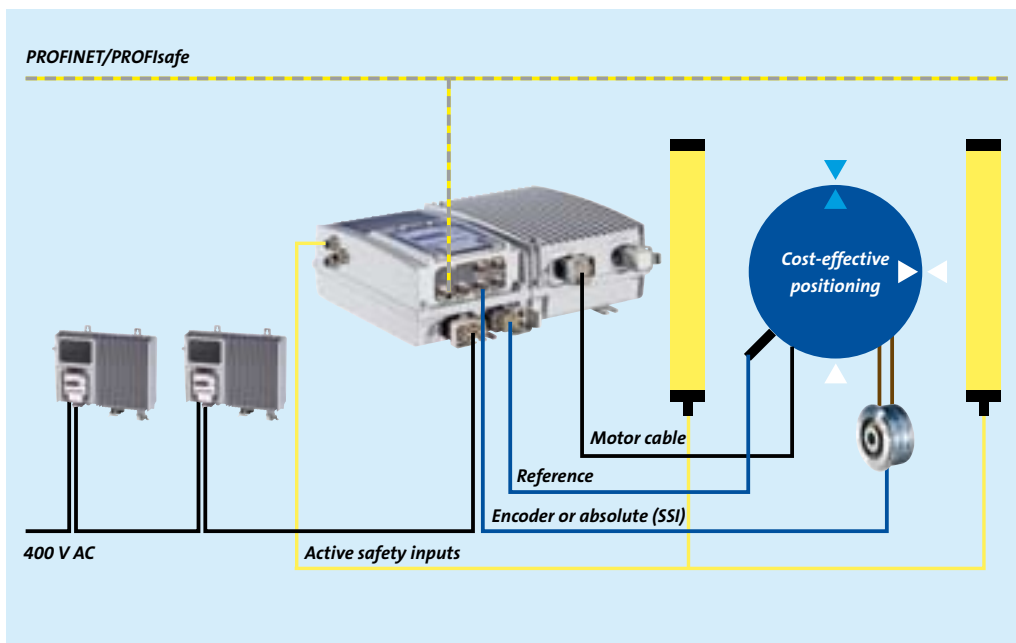

Solutions | transparent and cost-optimised

Pretested pluggable cables speed up commissioning and simultaneously reduce wiring overheads.

Less complex thanks to line topology

Distributed systems are often organised in lines. As such, transparent cabling results in a typical line topology. The 8400 protec is ideally positioned to support such topologies, as power bus and fieldbus are simply looped through from device to device. Yet, the 8400 protec also remains open for other types of installation, based on standard or hybrid cables.

Safety engineering cuts installation costs

Combining the two drive options below can reduce overall costs:

- ▶ Safety engineering with STO: no need to disconnect the mains voltage in the event of a safety incident.
- ▶ Integrated 48 W power supply unit for the local supply of sensors and actuators: eliminates the need for power supply units in the control cabinet and long supply cables.

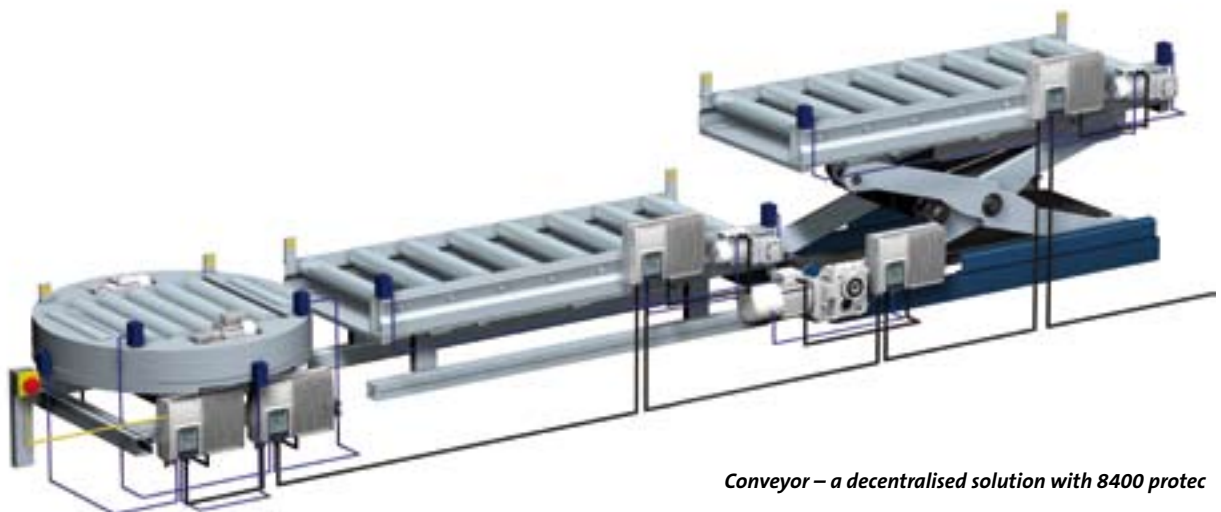
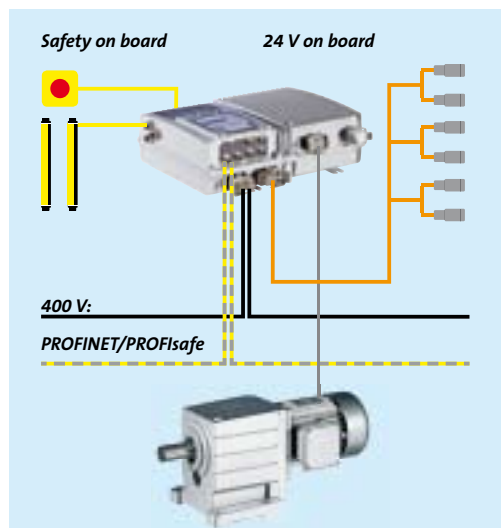
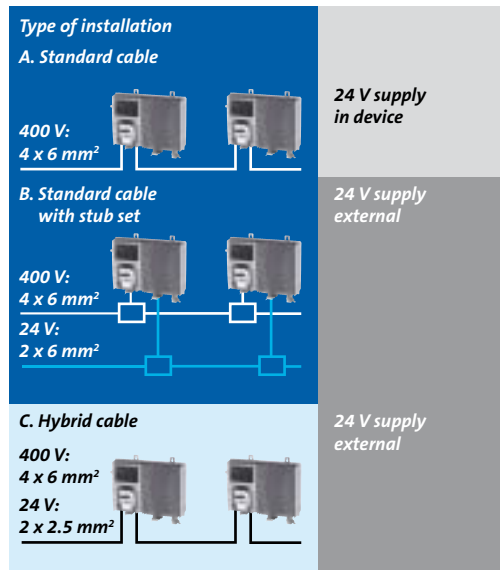

Conveyor – a decentralised solution with 8400 protec

Technical data

| | | | | | |
|---------------------------|-------------------------|---|-----|-----|-----|
| Typ. motor power (4-pole) | P _{rated} [kW] | 0.75 | 1.5 | 3 | 4 |
| Mains voltage range | U _{mains} [V] | 3/PE AC 320 V -0% ... 550 V +0%; 45 Hz -0% ... 65 Hz +0% | | | |
| Rated output current | I _{rated} [A] | 2.4 | 3.9 | 7.3 | 9.5 |
| Overload | | 150% (60 s) 200% (3 s) | | | |
| Dimensions | | | | | |
| Height | H [mm] | 260 | | | |
| Width | W [mm] | 353 | | 434 | |
| Depth | D [mm] | 110 | | 148 | |
| Climatic condition | | 1K3 (temperature: -25°C ... +60°C) 2K3 (temperature: -25°C ... +75°C) 3K3 (temperature: -25°C ... +55°C), derating above 45°C (2.5% /K) | | | |
| Enclosure | | IP65 | | | |

Interfaces

| Version | StateLine | HighLine |
|---|---|----------|
| Type of mounting | Wall-mounted device | |
| Inputs/outputs Digital inputs/outputs Analog input | 4/2 or 6/0 1 | |
| Interfaces Mains connection Motor connection Control terminals Communication connection – PROFINET version | HAN Q4/2 HAN Q8 M12 connector M12 connector AIDA standard Push-pull connector type 14 | |
| Basic functions | Integrated brake control for motor brake Various service switches Safety options Internal or external 24 V supply Internal or external brake resistor | |
| Communication | PROFIBUS PROFINET CAN | |
| Safety options SO10 SO20 SO30 | 1 safe input; STO, SS1 PROFIsafe; STO, SS1, OMS, ES 2 safe inputs; PROFIsafe; STO, SS1, OMS, ES | |

It's good to know | why we are there for you



"Our customers come first. Customer satisfaction is what motivates us. By thinking in terms of how we can add value for our customers we can increase productivity through reliability."



Vitamin L: *Lenze drive and automation solutions*



"We will provide you with exactly what you need – perfectly co-ordinated products and solutions with the right functions for your machines and installations. That is what we mean by 'quality'."



"Take advantage of our wealth of expertise. For 60 years now we have been gathering experience in various fields and implementing it consistently and rigorously in our products, motion functions and preprepared solutions for industry."



"We identify with your targets and strive towards a long-term partnership which benefits both sides. Our competent support and consultation process means that we can provide you with tailor-made solutions. We are there for you and can offer assistance in all of the key processes."

You can rely on our service. Expert advice is available 24 hours a day, 365 days a year, in more than 30 countries via our international helpline: 008000 24 Hours (008000 2446877).

www.Lenze.com

13317190