



Frequency inverter **8200 vector**  
Motor inverter **8200 motec**

Use with pumps and fans



**Lenze**

# Impressive cost benefits

With the 8200 vector and 8200 motec



Those who practise effective energy management know that energy costs are influenced by many factors. Using 8200 vector and 8200 motec frequency inverters in pumps and fans is a good starting point to reduce energy consumption.

Various ways of combining the products with application-specific modules mean they are able to take on many control and monitoring functions, and they prove their worth by reducing operating costs.

Which of our two inverters you choose will depend entirely on your requirements and may also be determined, for example, by whether you use centralised control cabinet technology or locate the inverter directly on the motor.



8200 vector



8200 motec

# Ventilators and fans | In operation

## With the 8200 vector

Ventilators and fans can be controlled via analog signals or fieldbus communication. In both cases, the 8200 vector frequency inverter with IP 20 protection provides a high degree of flexibility, thanks to its plug-in terminal and bus modules. This makes it very easy to integrate the 8200 vector frequency inverter into building automation, for example. As well as steplessly controlling the speed of inlet and exhaust fans, the 8200 vector can also take on many controlling and monitoring functions, e.g. a measured pressure or



temperature value can be evaluated directly in the inverter using the integrated PID controller.

### Advantages:

- ▶ Lowest possible energy consumption thanks to adjustable square load characteristics
- ▶ Noiseless operation, with switching frequencies of up to 16 kHz
- ▶ Integrated PID controller
- ▶ Electronic V-belt monitoring
- ▶ Square root scaled input to calculate volume flow from a pressure measurement
- ▶ Numerous communication options with DDC stations or GLT via PROFIBUS-DP, CANopen, INTERBUS, AS-i and RS232/485, amongst others

## With the 8200 motec

The 8200 motec frequency inverter is the solution for direct use on the motor. Installing the inverter directly on the motor or in its immediate vicinity saves space in the control cabinet and also saves on installation costs. The 8200 motec is designed with IP 65 protection.

As well as a saving in energy costs thanks to the adjustable square load characteristic, the need for load gauges and signal lines required for monitoring a V-belt is also eliminated, as the 8200 motec takes over this task.

Changes in operating conditions can be dealt with by simply converting or retrofitting the 8200 motec.

### Advantages:

- ▶ Frequency inverter with IP 65 protection ensures safe operation in harsh conditions.
- ▶ Control cabinet space reduced
- ▶ Numerous monitoring options



# Pumps | In operation

## With the 8200 vector

### Used in sequential switching, e.g. for refrigeration compressors or booster stations

Frequently, many of these systems are fitted with two pumps/compressors. If one unit fails, the second unit ensures supply to the consumers. The 8200 vector frequency inverter is suitable for use here, as the system usually only runs in partial load.

The first unit is matched to the load with a stepless adjustable speed. The second unit is controlled by the inverter, and is switched on and off as required. The inverter, therefore, takes over control of the system as a whole.

### Advantages:

- ▶ Stepless adjustment to actual requirements
- ▶ Reduction of start-up current
- ▶ Avoidance of pressure surges and mechanical resonance
- ▶ Power increase above the limit set by mains frequency to cover peak loads
- ▶ Savings on control components
- ▶ Change-over from manual to remote mode
- ▶ Minimum frequency limiting function for protection against running dry or lack of lubrication
- ▶ Adaptation of setpoint to operational performance of pump

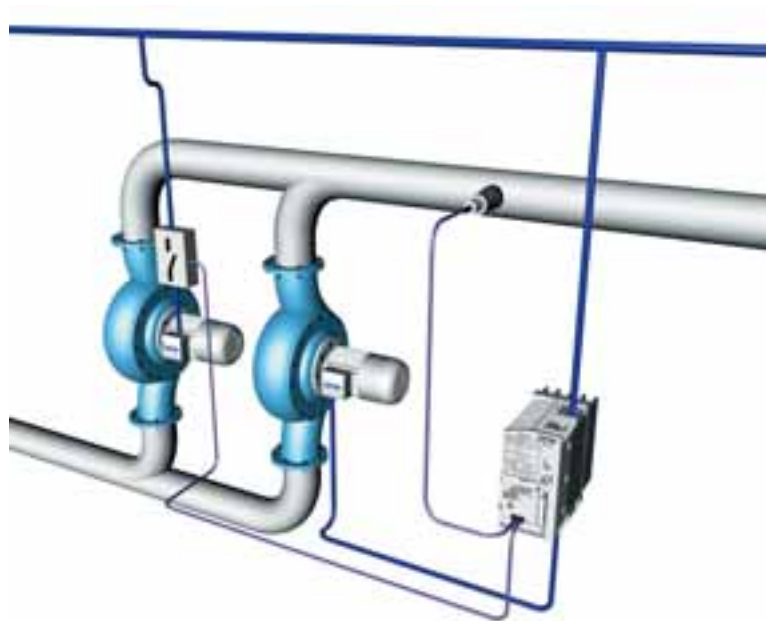

## With the 8200 motec

### Used, for example, in circulating systems within heating systems

Hot water is fed to the supply systems using controlled pumps. Pressure surges are avoided by sensitive, smooth speed control and masking of mechanical resonance. This considerably reduces wear on the system.

The process controller integrated in the 8200 motec frequency inverter as standard offers the option to control temperature or pressure without the need for additional components.

### Advantages:

- ▶ Cost savings through reduced installation and assembly expenditure
- ▶ Reduction in EMC problems (radio interference level B integrated as standard)
- ▶ Processes controlled by internal PID controller



# Selected case studies

With the 8200 vector  
and 8200 motec

## The Louvre

The Louvre is one of the most important museums in the world. Every day, thousands of visitors from all over the world gaze at the celebrated works of art it houses. HVAC technology is required in order to protect the precious exhibits from harmful environmental influences. It keeps the climate in the room constant, day and night, and ensures that the art can be enjoyed in optimum conditions.

### Our solution:

#### Air conditioning system with Lenze frequency inverters

Lenze drives are being used in the reception area and the new wing of the museum. The outside air is climatically conditioned and fed to individual exhibition rooms. The principle of source ventilation is used to ventilate the rooms, so that the conditioned air flows in a steady manner, with minimum turbulence. In order to ensure optimum climatic conditions in the rooms at all times, the way in which the frequency inverters control the inlet and exhaust ventilators varies depending on the number of visitors.



## Munich Airport Centre

The Munich Airport Centre (MAC) in the new Munich airport is always at a pleasant temperature. The MAC is a venue for events, a shopping centre and office space all in one, all of which make varying demands on ventilation technology. These demands are met by environmentally-friendly energy management, which achieves optimum room ventilation whilst using a minimum of energy.

### Our solution:

#### Volume flow control with Lenze frequency inverters

Optimum air conditioning is achieved by means of more than 40 frequency-inverter-controlled ventilator drives at power ratings of between 2.2 kW and 40 kW and throughput is 30,000 m<sup>3</sup> of air per hour at peak energy conservation levels. Inlet and exhaust ventilator speed depends on air humidity and actual temperatures. Operating costs can, therefore, be minimised by controlling the required volume flow exactly.



## Hamelin Solar Community

In the Technology Tower at the heart of the housing development, forward-looking, environmentally-friendly energy sources are used to supply power and heat. The heat supply is based on a two-step heat pump process and a solar power system with a movable panel which is always optimally aligned with the sun.

### Our solution:

#### Heat pumps with Lenze frequency inverter

In this case, the heat source is water from the River Weser, pumped into the supply buildings in the primary circuit via a pressure pipe. The temperature is increased to approximately 15 °C by means of two compressors controlled by frequency inverters in the central heat pump, then circulated via a further heat exchanger to the secondary circuit for heating homes. A second heat pump, whose heating power is designed in line with the heating requirements of the house, is located within all the houses. The circulating pumps found in the water circuits are also operated by frequency inverters, in order to adjust the volumetric capacity in accordance with requirements.



## Agricultural milking plants

Nowadays, even agriculture is affected by rationalisation and automation. For example, up to 32 cows can be simultaneously milked in Gascoigne Melotte's milking installations. Low-maintenance, robust, speed-controlled side-channel blowers from Gardner Denver Elmo Technology are used to pump and transfer the milk.

### Our solution:

#### Side-channel blower with 8200 motec

The 8200 motec is mounted directly on the motor and efficiently controls speed. The side-channel blower achieves increased power density and an excellent dynamic response thanks to the wide speed setting range and high load reserves.

Speed control ensures automatic adaptation to the process. Operation at the required load level saves energy. The need for hydraulic actuators and central control cabinets is eliminated by using a side-channel blower with “integrated” inverter. Losses incurred by controlling air leakage are also eliminated and savings are made on material costs.



# Brief profile | 8200 vector and 8200 motec

## 8200 vector

- ▶ Power range  
0.25 kW ... 7.5 kW, 230 V/240 V  
0.55 kW ... 90 kW, 400 V/500 V
- ▶ IP 20 degree of protection
- ▶ Switching frequency 1, 2, 4, 8, 16 kHz
- ▶ Output frequency up to 650 Hz
- ▶ Integrated RFI filter,  
optional footprint filter
- ▶ Motor protection via PTC input
- ▶ PID controller
- ▶ Freely-programmable inputs/outputs
- ▶ Freely-programmable relay output
- ▶ Integrated brake transistor  
(up to 11 kW)
- ▶ Interfacing with the most common  
fieldbuses
- ▶ UL/cUL approval



**Stuttgart Stock  
Exchange -**  
*Thanks to the  
8200 vector, brokers can  
stay cool under pressure.*



## Advantages

- ▶ Plug-in connections reduce assembly  
and installation times.
- ▶ Integrated control and monitoring  
functions reduce system costs.
- ▶ Plug-in modules increase application  
flexibility.
- ▶ Fast commissioning, thanks to  
preset standard configuration.
- ▶ Compact design saves space in the  
control cabinet.
- ▶ Automatic motor identification  
reduces commissioning time.
- ▶ Password protection prevents  
unwanted access.

## 8200 motec

- ▶ Power range  
0.25 kW ... 0.37 kW, 230 V/240 V  
0.55 kW ... 7.5 kW, 400 V/500 V
- ▶ IP 65 degree of protection
- ▶ Switching frequency 2, 4, 8, 16 kHz
- ▶ Output frequency up to 650 Hz
- ▶ Radio interference level B
- ▶ Motor protection via PTC input
- ▶ PID controller
- ▶ Freely-programmable inputs/outputs
- ▶ Freely-programmable relay output
- ▶ Integrated brake transistor
- ▶ Interfacing with the most common fieldbuses
- ▶ UL/cUL approval
- ▶ Suitable for wall or motor mounting

### Advantages

- ▶ EMC requirements are reduced.
- ▶ No long shielded motor or control cables are required.
- ▶ No control cabinet is required.
- ▶ Processes are controlled by an integrated PID controller.
- ▶ Simple integration into networked automation systems, e.g. PROFIBUS.
- ▶ Central control load is reduced by the frequency inverter's integrated monitoring functions.



*Bottrop Alpine Centre -  
Lenze inverters provide the  
optimum temperature for  
year-round skiing fun.*

# Technical data | 8200 vector frequency inverter

## Types, mains voltage range and dimensions

Type	Rated power [kW]	Increased rated power [kW]	Supply voltage [V] (45 ... 65 Hz)	Dimensions (H x W x D) [mm]
E82xV251K2C	0.25	0.37	230/240 V 1 x 180 ... 264 V ± 0%	120 x 60 x 140
E82xV371K2C	0.37	–		
E82xV551K2C	0.55	0.75	230/240 V 1 x 180 ... 264 V ± 0% 3 x 100 ... 264 V ± 0%	180 x 60 x 140
E82xV751K2C	0.75	1.1		240 x 60 x 140
E82xV152K2C	1.5	2.2		
E82xV222K2C	2.2	–		
E82xV302K2C	3.0	4.0	230/240 V 3 x 100 ... 264 V ± 0%	240 x 100 x 140
E82xV402K2C	4.0	–		240 x 125 x 140
E82xV552K2C	5.5	7.5		
E82xV752K2C	7.5	–	400/500 V 3 x 320 ... 550 V ± 0%	180 x 60 x 140
E82xV551K4C	0.55	0.75		240 x 60 x 140
E82xV751K4C	0.75	1.1		
E82xV152K4C	1.5	–		240 x 100 x 140
E82xV222K4C	2.2	3.0		
E82xV302K4C	3.0	4.0		
E82xV402K4C	4.0	5.5		240 x 125 x 140
E82xV552K4C	5.5	–		
E82xV752K4C	7.5	11		350 x 250 x 250
E82xV113K4C	11	–		
E82xV153K4B	15	22		
E82xV223K4B	22	30		
E82xV303K4B	30	37		
E82xV453K4B	45	55	400 V 3 x 320 ... 550 V ± 0%	510 x 340 x 285
E82xV553K4B	55	75		591 x 340 x 285
E82xV753K4B	75	90		680 x 450 x 285
E82xV903K4B	90	110		

## Functions and features

Degree of protection	IP 20						
Interference suppression limit value classes A and B in accordance with EN55011	Integrated in power range up to 11 kW, optional as compact footprint filter						
Environment temperature range	0 ... +50°C (with power reduction above +40°C)						
Approvals	CE, UL/cUL						
Switching frequencies	2, 4, 8, 16 kHz						
Standard functions	PTC input, PID controller, motor parameter identification and adaptation, 1 programmable relay output, S ramps, level inversion, skip frequencies, fixed speeds, four parameter sets (switchable online), password protection, bipolar setpoint processing, etc.						
Open-loop and closed-loop control methods	vector control, V/f characteristic control (linear, quadratic), torque control						
Drive characteristics	1.8 x M <sub>rated</sub> (60 s), torque setting range 1:10 for 3 ... 50 Hz, speed setting range 1:50 with M <sub>rated</sub> (50 Hz), concentricity ± 0.1 Hz						
Function modules	I/O modules	Standard I/O (PT)	Analog IN 1	Analog OUT 1	Digital IN 4*	Digital OUT 1	Freq. OUT -
		Application I/O (PT)	2	2	6*	2	1
		* With option of 1 frequency input					
Bus modules		INTERBUS PT, PROFIBUS-DP PT, LECOM-B (RS 485) PT, CAN PT (system bus), DeviceNet PT, CANopen PT, AS-Interface PT, CAN-I/O (system bus) PT					
Options		Keypad, LECOM-A/B (RS232/485), LECOM-LI (optical fibre), brake control module, external brake resistor					

# Technical data | 8200 motec frequency inverter

8200 motec  
frequency inverter

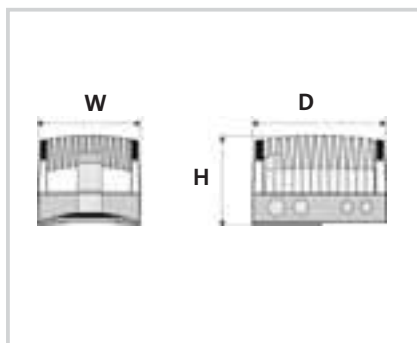

Can be combined with three-  
phase AC motor

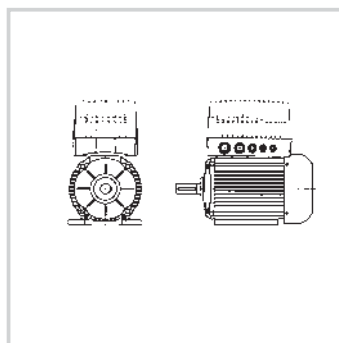

Can be combined with  
geared motor

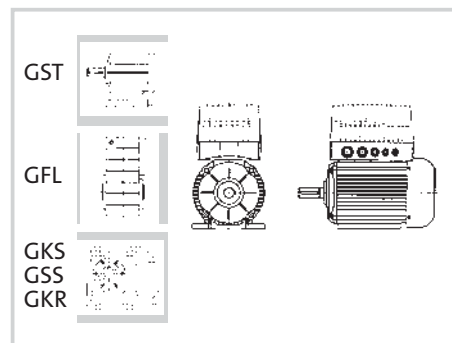

## Types, mains voltage range and dimensions

Type	Rated power [kW]	Increased rated power [kW]	Supply voltage [V] (45 ... 65 Hz)	Dimensions (H x W x D) [mm]
E82MV251_2B	0.25	0.37	230/240 V 1 x 180 ... 264 V ± 0%	100 x 138 x 190
E82MV371_2B	0.37	0.55		
E82MV551_4B	0.55	0.75	400 V 3 x 320 ... 550 V ± 0%	151 x 156 x 202
E82MV751_4B	0.75	1.1		
E82MV152_4B	1.5	2.2		
E82MV222_4B	2.2	3.0		167 x 176 x 230
E82MV302_4B	3.0	4.0		
E82MV402_4B	4.0	5.5		Motor mounting: 163 x 211 x 325 Wall mounting: 223 x 211 x 325
E82MV552_4B	5.5	7.5		
E82MV752_4B	7.5	–		

## Functions and features

Degree of protection	IP 65, protection against accidental contact to Nema 250 Type 4 (3 ... 7.5 kW for wall mounting: IP 54)						
Interference suppression limit value classes A and B in accordance with EN55011	Integrated as standard						
Environment temperature range	-20 ... +60°C (with power reduction above +40°C)						
Approvals	CE, UL, cUL						
Switching frequencies	2, 4, 8, 16 kHz						
Standard functions	PTC input, PID controller, integrated brake transistor, motor parameter adaptation and adjustment, programmable relay output, S ramps, level inversion, skip frequencies, fixed speeds, four parameter sets (switchable online), password protection, bipolar setpoint processing, etc.						
Open-loop and closed-loop control methods	vector control, V/f characteristic control (linear, quadratic), torque control						
Drive characteristics	1.8 x M <sub>rated</sub> (60 s), torque setting range 1:10 for 3 ... 50 Hz, speed setting range 1:50 at M <sub>rated</sub> (50 Hz), concentricity ± 0.1 Hz						
Function modules (option)	I/O modules	Standard I/O	Analog IN 1	Analog OUT 1	Digital IN 4*	Digital OUT 1	Freq. OUT –
		Application I/O	2	2	6*	2	1
		* With option of 1 frequency input					
Bus modules	INTERBUS, PROFIBUS, LECOM-B (RS485), system bus (CAN), CANopen, DeviceNet, AS-Interface						
Options	Switch potentiometer unit, diagnosis terminal with keypad or RS232 interface, brake control module, external brake resistor, mains bus connector						

# It's good to know | why we are there for you



*"Our customers come first. Customer satisfaction is what motivates us. By thinking in terms of how we can add value for our customers we can increase productivity through reliability."*



*"The world is our marketplace. We develop and manufacture internationally. Wherever you are in the world, we are nearby."*



*"We will provide you with exactly what you need – perfectly co-ordinated products and solutions with the right functions for your machines and installations. That is what we mean by 'quality'."*



*"Take advantage of our wealth of expertise. Since 60 years we have been gathering experience in various fields and implementing it consistently and rigorously in our products, motion functions and preprepared solutions for industry."*



*"We identify with your targets and strive towards a long-term partnership which benefits both sides. Our competent support and consultation process means that we can provide you with tailor-made solutions. We are there for you and can offer assistance in all of the key processes."*

**You can rely on our service. Expert advice is available 24 hours a day, 365 days a year, in more than 30 countries via our international helpline: 008000 24 Hours (008000 2446877).**

**[www.Lenze.com](http://www.Lenze.com)**

13228878